

Consumer's Guide to Photovoltaic (PV) Systems



Wisconsin Division of Energy
Wisconsin Solar Use Network (WisconSUN)
Focus on Energy Renewable Energy Program

Summer, 2003

Cover photograph: the Bahr home, Madison WI. The home's 1.6 kW of solar electric shingles (Made by UniSolar) generate 100% of the home's electricity needs. Photograph Niels Wolter, WisconSUN

This Consumer's Guide was adapted with permission from the National Renewable Energy Laboratory (NREL), in Golden, Colorado.

Table of Contents

Introduction	1
Background	1
What is a photovoltaic system?	1
Investing in a PV System	2
Why should I buy a PV system?	2
Is my home or business a good place for a PV system?	4
Can you orient your system for good performance?	4
Is your site free from shading by trees, nearby buildings or other obstructions?	4
<i>Your Solar Rights</i>	5
Do you have enough area on your roof or property?	5
Where are PV systems usually mounted?	5
What are roof-mounted PV system options?	6
Over the roof PV panels	6
Solar electric roofing panels	7
What are the different PV system ground mounting options?	7
<i>Off-grid PV Systems</i>	8
Are there PV system electrical losses?	8
What size should the PV system be?	9
Energy efficiency first!	9
Then size your PV system	9
<i>Wisconsin Residential Electricity Use</i>	10
How much will my PV system save me?	10
How much does a PV System cost?	11
What is the installed price of a PV System?	11
Are incentives available to help reduce the cost?	11
Wisconsin Incentives and Assistance	11
Focus on Energy	11
Personal Property Tax Exemption	12
Net Energy Billing	12
Federal Incentives	12
How can I finance the cost of my PV system?	13
Residential systems	13
Commercial systems	13
Selecting a PV Installer	14
Who sells and installs PV systems?	14
Should you install your own PV system?	14
How do I choose among PV providers?	14
How do I choose among competing bids?	15
<i>What about warranties?</i>	16
Before Purchasing a PV system	16
What about permits?	17
Homeowners association codes	17
Building permits	17
PV systems and the National Electrical Code	17
What about liability insurance?	18
How do I get an interconnection agreement?	18
Who pays for interconnecting?	18
How do I get a net energy billing?	19
What about utility and inspection sign-off?	19
What are the steps for getting a PV system installed?	20
Further Resources	21
mreainfo@wi-net.com	21

Introduction

Are you thinking of buying a photovoltaic (PV, or solar electric) system for your home or business? If so, this guide provides basic information that you will need to know.

Investing in a PV system allows you to produce your own electricity without noise, air pollution or moving parts¹ while using a clean, renewable fuel resource. Many people purchase PV systems to be better environmental stewards. A PV system will never run out of fuel and it won't increase energy imports. It will also create jobs in Wisconsin and reduce the economic impacts caused by sudden increases in the cost of fossil fuels. Due to these unique characteristics, PV technology is often thought of as the ultimate energy source for the 21st century. Although systems are still expensive, they are becoming more affordable, and a number of state and federal incentives are available to help reduce their costs.

This guide summarizes the process of buying a grid-tied solar electric system. This is not a technical guide for designing or installing your system—for that information you need to consult an experienced full service solar electric (or PV) installer². A solar electric system is a substantial investment, and as with any investment, expert assistance and careful planning will help you make the right decisions.

Background

What is a photovoltaic system?

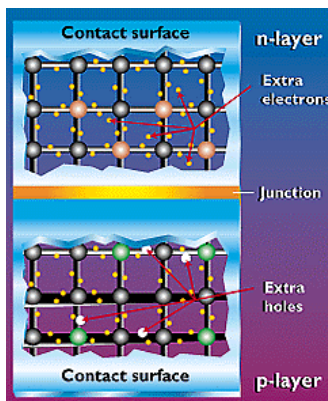

A photovoltaic (PV) material converts sunlight directly into electricity. PV cells generate electricity whenever photons (the mass-less particles that make all light) strike the photovoltaic material and move loosely held electrons (Figure 1). It works any time the sun is shining, but more electricity will be produced when the sun's rays are brighter and are striking the PV cells directly (perpendicular to the PV cells). Unlike solar systems for heating water, PV technology generates electricity, not heat.

Figure 1. Cross section of a Photovoltaic Cell. Note the “n-layer” which contains loosely held electrons and the “p-layer” which has holes for electrons. As photons strike the n-layer, electrons move into the p-layer creating an electric potential and thus electrical current.

¹ If the PV panels are placed on a tracking rack the PV system will include moving parts.

The basic building block of PV technology is the solar "cell" (Figure 2). PV cells are wired together to produce a PV "module"—the smallest PV component sold commercially. PV modules range in power output from about 10 watts to 300 watts.

A PV system tied to your electric provider's distribution grid (or "grid-tied PV") consists of one or more PV modules connected to an inverter. An inverter changes the system's direct-current (DC) electricity to alternating current (AC). The AC current is compatible with the electric provider's grid, and able to power devices such as lights, appliances, computers and televisions. When excess power is produced by the PV system, it can be put back on to the electric grid. To improve your power reliability and security, you can include batteries in the system to provide back-up power.

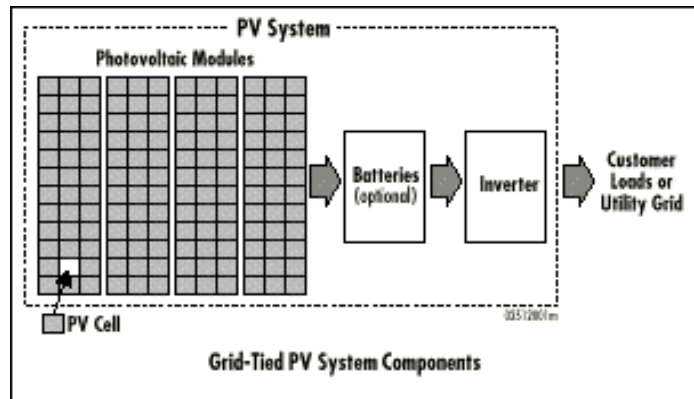

Figure 2. Grid-Tied PV system

Before you decide to buy a PV system, you should understand that:

- PV systems produce power intermittently because they work only when the sun is shining. This is not a problem for grid-tied PV systems because your electric provider is there to supply your additional electricity requirements.
- PV-generated electricity is more expensive than conventional utility-supplied electricity. Improved manufacturing has reduced the cost to less than one percent of what it was in the 1970s.

Investing in a PV System

Why should I buy a PV system?

Many people ask, what is the payback period of a PV system? The truth is that given current energy prices, the payback period is often longer than the system's expected life. There are several different methods of assessing the economics of a grid connected PV system:

- The simple payback period is between 50 and 90 years³.

² A listing of full service solar electric installers is available from the Wisconsin Renewable Energy Yellow Pages (available at the Focus on Energy webpage www.focusonenergy.com).

³ The PV system is assumed to cost \$7,500 to \$9,000 per kW and generate between 1200 and 1600 kWh/year. The value of electricity is assumed to be 8.5 cents/kWh.

- If we assume that the real rate of electricity price increase is two percent per year, a solar electric system will pay for itself in 40 to 50 years
- If the system's costs are amortized over its estimated 40-year life; its cost is about 40 to 60 cents per kilowatt-hour⁴. This is roughly five to eight times the price that most Wisconsin residents now pay for electricity.

Purchasing a PV system is like paying years of electric bills up front and avoiding future price increases. To avoid the high initial cost, financial incentives are available and financing can be used to spread the cost over many years.

There are many reasons to install a solar electric system. People who purchase PV systems are usually not making their decision based on the economics. Investing in PV is similar to other purchases that are made for a variety of reasons. We don't just think about price when buying organic food, choosing the right car, or buying the appropriate recreational equipment. None of these decisions is based primarily on payback period.

Non-economic reasons for purchasing a PV system include:

- Making a public statement about concern for the environment
- Investing in an energy-producing property improvement that will to reduce future utility bills
- Increasing power security
- Reducing or eliminating electricity purchases, and avoiding future electricity price increases
- Wanting to use an amazing technology

At schools or other public buildings the energy produced by a PV system is a secondary benefit when compared to its educational impacts. At some commercial locations, the PV system may primarily contribute public relations benefits. Whatever the reason, solar energy is widely thought to be one of the most important energy sources of the future!

⁴ This assumes a 40-year loan for the full amount of the PV system at an interest rate of 7%. The PV system is assumed to cost \$7,500 to \$9,000 per kW and generate between 1200 and 1600 kWh/year.



Photograph 1. The Ritger Law Office, Random Lake, WI has a 5.12 kW solar electric system composed of thin film panels laminated onto the standing seam metal roof. Note the darker colored PV panels installed on the upper gable of the roof. The office also employs daylighting, a geothermal heat pump system and in-floor radiant heating. Photograph by Niels Wolter, WisconSUN

Is my home or business a good place for a PV system?

Can you orient your system for good performance?

A PV system designed for maximum power production requires clear and unobstructed access to the sun's rays for most of the day throughout the year. You can begin your own solar assessment simply by noting whether the south side of your site has trees or buildings shading it. A PV installer has the tools needed to trace the sun's annual path at your location that will help you make a more specific determination of your solar energy resource.

The orientation of your PV system (the compass direction that your system faces and the angle at which it tilts) will affect performance. In Wisconsin, the sun is mostly in the southern half of the sky and is higher in the summer and lower in the winter. Usually, the best location for a PV system is a south-facing roof, but roofs that face east or west may also be acceptable. Flat roofs also work well for solar systems because the PV modules can be mounted on racks tilted toward the south at the optimal angle. The optimal tilt angle for solar electric panels in Wisconsin is roughly 25 degrees to 45 degrees from horizontal.

If a rooftop installation cannot be used, solar modules can also be placed on the ground, either on a fixed rack, or on a "tracking" rack that follows the sun to orient the PV modules for maximum performance.

Is your site free from shading by trees, nearby buildings or other obstructions?

To get the most power out of your PV system, the modules must have a clear "view" of the sun, unobstructed by trees, roof gables, chimneys, buildings or other nearby features. Shading during the core hours of the day (10 a.m. to 3 p.m.) will substantially reduce the system's output.

Your Solar Rights

The State of Wisconsin provides you with the right to protect existing access to the solar resource. Residential, commercial and industrial owners of PV systems can apply for permits that will guarantee this access except in cases where an obstruction already exists or if the construction of such an obstruction is well into the planning stages. The permit cannot be requested for an existing obstacle to the solar resource. This access is available for all types of active solar (and wind) systems.

Do you have enough area on your roof or property?

PV system area requirements are based on your electricity production needs and on PV module conversion efficiency (Table 1). Note that crystalline, multi-crystalline or poly-crystalline PV modules have about twice the efficiency of thin film or amorphous panels, thus they require about half the roof area.

Most residential systems require as little as 50 square feet (for a small "starter" system), up to as much as 1,000 square feet. Commercial systems can be even larger. If your location limits the physical size of your system, you may need to install a system that uses higher-efficiency PV modules. The cost per kilowatt of higher-efficiency modules is about the same as low-efficiency modules, so this may not add to your system's price. System sizing and mounting options are discussed later in this guide and should also be discussed with your PV provider.

Table 1. Roof Area Needed for PV Systems (square feet)

PV Panel Efficiency (%)*	Total PV Panel Rating in kilowatts (kW)							
	0.1 kW	0.25 kW	0.5 kW	1 kW	2 kW	4 kW	10 kW	100 kW
8	15	38	75	150	300	600	1,500	15,000
12	10	25	50	100	200	400	1,000	10,000
16	8	20	40	80	160	320	800	8,000
17.5	7	18	36	70	140	285	700	7,000

The efficiency of crystalline panels is typically between 14% and 16%. The efficiency of a thin film or amorphous panels is around 8%. The most efficient commercial modules have an efficiency of 17.5%. This table does not account for PV system (i.e., inverter, wire, temperature, shading and snow cover) losses, which are discussed later.

Where are PV systems usually mounted?

Commonly PV systems are either mounted on rooftops or on the ground. They can also be incorporated into building design as shade screens, windows and siding.

What are roof-mounted PV system options?

Rooftop PV systems can either be mounted in racks on top of existing roofing materials, or can replace the roofing materials themselves. Roofing replacements include solar electric shingles, standing seam metal roofing or slate roofing. These options both generate electricity and serve as the home's weather barrier.

Rack-mounted PV panels

PV panels mounted on top of roofing are typically composed of framed rectangular PV modules installed on brackets (photograph 2) or racks. This is the most common type of mounting for urban PV systems in Wisconsin. The drawbacks of these panels include:

- Panels must be removed whenever the roofing materials are replaced or repaired
- Installation of brackets and racks may result in leaks, and may affect the warranty on existing roofing materials
- Some people find them unattractive and some subdivisions do not allow roof mounted "solar panels"

However, rack-mounted roof panels do tend to cost less than solar electric roofing materials.

A rack-mounted PV system can be installed on any type of roof, but installation costs will vary. Typically, composition shingles are easiest to work with, and slate is the most difficult. In any case, an experienced PV provider will know how to work on all roof types and can use roofing techniques that eliminate the possibility of leaks. Ask your PV provider how the PV system affects your roof warranty.



Photograph 2, The Bircher home in De Pere, WI includes two small PV panels (right) mounted over shingles, total capacity 550 watts, as well as two solar water-heating panels (left). The PV system meets roughly 15% of the home's electricity needs. Photograph Chip Bircher

If your roof will need to be replaced in the near future, you may want to combine its replacement with installation of the PV system to avoid the cost of removing and reinstalling your PV system.

Solar electric roofing panels

Solar electric roofing panels also serve as roofing materials, providing the customary weather protection standard roofing materials provide. These panels are available as shingles (cover photograph), standing seam metal roofing (photograph 1) and slate roofing (photograph 3). Of the three, the most economical is field-laminated standing seam metal roofing. Solar electric roofing will cost 0% to 40% more than rack-mounted PV panels.



Photograph 3, The University of Wisconsin – Madison, Madison, WI. This 8.5 kW system uses PV modules laminated onto 700 man-made roofing slates. Photograph Niels Wolter, WisconSUN.

Panels integrated as part of the roof are best installed at the time of roof replacement or during the initial

construction of the home or addition. For the urban setting they may become the preferred type of PV system.

What are the different PV system ground mounting options?

Ground mounted systems are commonly installed in rural Wisconsin or in situations where the roof is not suitable. Commonly these systems use racks that continually adjust the orientation of the PV panels to follow the progression of the sun during the day. This increases system output as well as cost. Four types of ground-mounted systems are available:

- Fixed racks – are fixed at one orientation, typically facing due south and sloping at the angle of the latitude at the site. In Wisconsin an unshaded fixed mounted system will generate about 1200 to 1300 kWh per year per kilowatt of PV panels.
- Manually adjustable racks – allow the slope of the panels to be changed. Typically racks are adjusted four times a year (early February, May, August and November) and result in about a 12% output increase (compared to a fixed mount system).
- Single axis tracking racks – typically used on flat mounted panels that follow the sun east to west each day. Photo-eyes, a controller and a small electrical motor are needed to operate the system. Single axis tracking increases system output by about 25%. Single axis tracking systems are relatively rare.
- Dual axis tracking racks – continually orient the panels perpendicular to the brightest part of the sky (see photograph 4). Like the single axis tracking system they require additional components. In Wisconsin, dual axis tracking increases system output by about 31%. Dual axis tracking systems are common, particularly in rural areas.

Single and dual axis tracking systems have moving components so expect to do some maintenance. To optimize the economics of your PV system consider a dual axis tracking system.

Off-grid PV Systems

PV systems that are not connected to the electric provider's distribution grid will require batteries to supply a reliable source of power. The size of the battery bank depends on the electricity needs of the site and the days of storage the owner desires (three to seven days is common). Battery-based systems will require a charge controller and battery box. Quite often, a gasoline, diesel or propane generator (to help maintain batteries and support the site during prolonged periods of low sun) is included in off grid systems. Batteries require some maintenance and if treated well will last four to seven years.



Photograph 4. Grass Roots Health Food Store, Eagle River WI. Includes a 0.5 kW dual axis tracking PV system. (Typically systems are mounted on shorter poles.) Photograph David Koller, Grass Roots Health Foods

Are there PV system electrical losses?

Every solar electric system will experience power losses, so be prepared to get less than the rating of the panels. Electricity is lost due to shading and snow cover on the panels themselves, and then through wire losses, inverter losses, panel temperature losses and, if the system includes batteries, battery losses. PV professionals are well acquainted with this problem and can help specify equipment and design the system to minimize losses.

- Shading losses are created by objects, typically trees, between the panels and the sun. A line shadow across a PV system can drastically reduce its kWh production.
- Snow cover losses are caused by snow lying on the panels and blocking the sunlight. Sweeping snow off the panels reduces snow shading. Inclined panels naturally shed snow as they warm up in the sun. Snow losses of 2% to 5% are fairly common.
- Wire losses occur as electrons move through wiring. A commonly used estimate of wire losses is 2%.

- Inverter losses result from the natural inefficiencies of converting direct current to alternating current. Different inverters have different loss rates. For systems without batteries losses are commonly in the 5% to 10% range.
- Panel temperature losses occur because of the reduced efficiency of the PV panel as it heats up. For crystalline PV panels a panel-temperature loss estimate of 14% (on an annual basis) is commonly used for Wisconsin sites.
- Battery losses are highly variable depending on how the PV system is used.

As a result, a grid-connected PV system commonly has losses of between 23% and 31%. This means that if you purchase 1000 watts (or one kW) of PV panels⁵ they will deliver roughly 690 to 770 watts of electricity for use.

What size should the PV system be?

Energy efficiency first!

As a starting point, you should look at how you consume electricity⁶ and then implement energy efficiency measures. Simple energy efficiency measures can reduce your electric demand much more cost effectively than generating solar electric power. And, the less you use, the smaller your PV system needs to be.

Simple energy efficiency measures include:

- Replacing the electric hot water heaters and clothes dryers with natural gas, or propane appliances.
- Replacing old, inefficient air conditioners, refrigerators, freezers, dehumidifiers, etc. with new Energy Star[®] appliances.
- Decreasing the size of appliances, such as refrigerators and freezers.
- Replacing standard incandescent lights with high quality, compact fluorescent lights.

An old saying in the renewable energy business is “Energy Efficiency First.” Often five cents invested in energy efficiency can save you \$1 in the cost of a renewable energy system.

Then size your PV system

Once you have reduced your electricity usage, work with your PV provider to:

1. Examine your electricity needs,
2. Determine the fraction of your electricity usage the PV system should meet, and

⁵ As rated by manufacturers at standard test conditions (STC). STC is at 77° much lower than the average operating temperature of a PV panel in Wisconsin, which can reach well over 120° on a sunny day.

⁶ You can contact your electric provider and request your annual and monthly electricity usage.

3. Specify your PV system's siting, size and design to meeting your annual kWh production goal.

Wisconsin Residential Electricity Use

The average single family home in Wisconsin consumes about 10,000 kilowatt hours (kWh) per year. A more efficient single family home may consume 5,000 kilowatt hours (kWh) per year. Some Wisconsin families have reduced their usage to 2,500 kWh/year.

Fix-mounted one kilowatt (kW) PV system⁷ (unshaded, facing due south and titled between 25° and 45° will generate about 1200 to 1300 kWh per year⁸. Thus to meet 40% of the electricity requirements of an efficient home (2500 kWh/year usage), about 0.84 kilowatt (kW) (or 840 Watts) of PV panels are need.

How much will my PV system save me?

The value of your PV system's electricity will depend on how much you pay your utility for electricity and how much your utility will pay you for any excess that you generate.

Wisconsin's investor-owned⁹ and municipal utilities allow you to sell your excess electricity back to the utility at the retail rate. This is called "net energy billing". This will make it fairly easy for you to calculate the value of your electricity because you and your electric provider will pay the same price for each other's electricity.

The current average price for electricity for residential customers is about eight cents per kWh. A fix-mounted one kW PV system producing 1200 kWh/year will save roughly \$100 per year in electricity costs.

If your electric provider does not offer net energy billing¹⁰ (more on net energy billing later), determining the value of the electricity is much trickier because your excess electricity will not be worth as much as the electricity you actually use. In such a case, you will receive your utility's "avoided cost¹¹" which may be as low as 2.0 cents per kilowatt-hour—much less than the retail rate—for your excess power. In the case that your electric provider does not offer net energy billing, you may want to size your system to avoid generating electricity significantly beyond your actual needs.

⁷ One kilowatt of PV panels in direct sunlight for one hour will generate one kWh (i.e., one kilowatt of electricity in one hour).

⁸ Actual energy production from your system will vary by up to 20 percent from these figures, depending on your geographic location, the angle and orientation of your system, the quality of the components of your system, and shading/snow cover of your system.

⁹ Wisconsin's investor owned utilities include Alliant, Madison Gas and Electric, WE Energy, Wisconsin Public Service and Xcel Energy.

¹⁰ Many of Wisconsin's rural electric cooperatives do not provide net energy billing.

¹¹ Simply stated the avoid cost is the utility's cost of generating electricity.

How much does a PV System cost?

What is the installed price of a PV System?

Your system's price will depend on a number of factors, as summarized on Table 2.

Table 2. Estimated price for small PV systems of one to three kilowatts. Prices include all components, labor, shipping, and taxes.

Item	Cost per kilowatt (kW)
Grid-tied fixed mount	\$7,500- \$9,000
Dual axis tracker mount	Add \$1,000 - \$1,750
Battery back up for grid connected systems	Add \$2,000 - \$2,500
Using solar roofing panels	Add \$0 to \$3,000
Off-grid battery bank	Add \$2,500 to \$4,000

These prices are rough estimates. Your costs will depend on your system's configuration, your equipment options and other factors. Smaller systems tend to cost more per kW, while larger systems cost less per kW. Your local PV provider can provide you with estimates or bids.

Are incentives available to help reduce the cost?

A number of incentives are available from the state and federal governments as well as some utilities. For an up-to-date listing of incentives visit the Database of State Incentives for Renewable Energy DSIRE webpage (www.dsireusa.org).

Wisconsin Incentives and Assistance

Wisconsin Public Benefits Programs: All Wisconsin electric utilities are required to collect funds from electric ratepayers to implement energy-related programs that provide "public benefits". These funds support low income, energy efficiency and renewable energy programs. Many of Wisconsin's electric utilities, including all the investor- owned utilities, have combined their funds to create the Focus on Energy program. In general rural electricity cooperatives and many cooperative utilities are not participating in the Focus on Energy program, but have their own public benefits programs. Contact Focus on Energy or your electric provider to determine your eligibility.

Focus on Energy

The Focus on Energy Renewable Program provides both incentives and assistance.

Incentives include:

- Cash back rewards, which help fund PV systems based on their expected annual electrical output.
- Low Interest rate loans for existing homes.

Assistance services include:

- Information about PV, case studies, directory of PV installers and equipment vendors is available at www.focusonenergy.com or through the toll-free phone number 1-800-762-7077.
- Phone and e-mail project assistance, with solar experts.
- Solar site assessment at your project site.

Personal Property Tax Exemption

All Wisconsin taxpayers are exempt from paying additional property taxes when installing qualifying renewable energy equipment as a property improvement. This exemption is available for residential, commercial, industrial and utility sectors and covers the total value of the systems, without a size limit.

Net Energy Billing

When your PV system is tied to the electric distribution grid, net energy billing allows you to bank excess electricity with the utility at the retail rate. In other words your meter turns backwards. The idea behind net energy billing is that the electric grid is your battery. Net energy billing is available to customers of Wisconsin's investor-owned utilities and municipal utilities, and a number of the electric distribution cooperatives¹². Systems must have a rated capacity of 20 kW or less. If your electric provider allows net energy billing, confirm the exact buy-back rates.

For more information contact you local electric provider, or

Paul Helgeson,
Public Service Commission of Wisconsin,
P.O. Box 7854,
Madison, WI 53707-7854,
(608) 266 3905
helgep@psc.state.wi.us.

Federal Incentives

The U.S. government also provides financial support for PV technology through a tax credit for commercial uses of solar energy. This energy investment credit

¹² In addition to PV, eligible systems typically include solar thermal electricity, wind, biomass, hydro, alternative fuels, geothermal, waste, cogeneration, and conventional fossil-fueled generation.

provides businesses (but not individuals or utilities) with a 10 percent tax credit and 5½ year accelerated depreciation for the installed cost of the PV system¹³.

For an up-to-date listing of Federal incentives visit the Database of State Incentives for Renewable Energy DSIRE webpage at: <http://www.dsireusa.org> and click on “Federal Incentives”.

How can I finance the cost of my PV system?

There is nothing magical about financing the cost of purchasing and installing your PV system. Most of the options are similar to how any large purchase would be financed.

Residential systems

For eligible owners of existing single-family homes or duplexes, the Focus on Energy Program offers a low interest rate loan. Eligibility is based on whether or not your utility is part of the program.

Getting a bank loan or mortgage for a solar electric system may raise the eyebrows of loan officers simply because they have very little experience with PV and are uncertain of its resale value. Small community banks may have a more positive attitude about financing a PV system.

One way to finance PV systems for homes is through a mortgage loan. Mortgage financing options include your primary mortgage, a second mortgage such as a U.S. Department of Housing and Urban Development (HUD) Title 1 loan, or a home-equity loan that is secured by your property. There are two advantages to mortgage financing. First, mortgage financing usually provides longer terms and lower interest rates than other loans, such as conventional bank loans. Second, the interest paid on a mortgage loan is generally deductible on your federal taxes (subject to certain conditions). If you buy the PV system at the same time that you build, buy or refinance the house on which the PV system will be installed, adding the cost of the PV system to your mortgage loan is likely to be relatively simple and may avoid additional loan application forms or fees.

If mortgage financing is not available, look for other sources of financing, such as conventional bank loans. Remember to look for the best possible combination of low rate and long term. This will allow you to amortize your PV system as inexpensively as possible. Because your PV system is a long-term investment, the terms and conditions of your PV financing are likely to be the most important factor in determining the effective price of your PV-generated power.

Commercial systems

PV systems purchased for business applications are probably best financed through a company's existing sources of funds for capital purchases—usually Small Business Administration loans or conventional bank loans.

¹³ The cost of a commercial PV system can be depreciated over six years, 50% in year one, 20% in year 2, 12% in year 3, 7.2% in years 4 and 5, and 3.6% in year 6.

Selecting a PV Installer

Who sells and installs PV systems?

In some locations, finding a PV provider can be as simple as picking up the telephone directory and looking under "Solar Energy Equipment and Systems—Dealers." Be aware, however, that many of those listings are for solar water heating companies that may not have experience with solar electric systems.

Wisconsin has a directory of renewable energy professionals, called the "Wisconsin Renewable Energy Yellow Pages." It is available online at the www.focusonenergy.com web page, or by calling the Focus on Energy call center ((800) 762-7077). The Yellow Pages indicate which businesses provide the full suite of PV system services (i.e., design, sales, installation and maintenance) – known as "full service PV installers".

Should you install your own PV system?

Many people want to install their own PV system. Unless you are skilled in PV installation, you should consider hiring a professional. Wisconsin's standards for connecting a PV system to the grid require that it meet all national, state and local codes, so it is important to properly install your system. The last thing you want is a lightning strike destroying your inverter.

How do I choose among PV providers?

Wisconsin is home to a number of reputable contractors with experience in installing PV systems. To find an installer first consider PV providers closest to you, because the contractor's travel costs might add to your system price. Next, contact these providers and find out what products and services they offer. The following questions may give you a good sense of their capabilities.

- *Has the company installed grid-connected PV systems? If not, has it installed off-grid PV systems?*

Experience installing grid-tied systems is valuable because some elements of the installation—particularly interconnection with the local electric provider—are unique to these systems. Although installing a grid-tied system is different from installing an "off-grid" system, a competent company with PV experience should not be eliminated just because it has not installed grid-connected PV systems in the past. In fact, experience with off-grid systems is valuable because such systems are more technically complicated than grid-tied systems. Look for a company aware of your utility's interconnection application procedures and Wisconsin's Interconnection Guidelines.

- *How many years of experience does the company have installing PV systems?*

This issue speaks for itself: A company or contractor that has been in business a long time has demonstrated an ability to work with customers and to compete effectively with other firms. However in Wisconsin's PV market place there are only a few installers with long business histories. Wisconsin needs more

installers; so working with a new installer is good for the development of Wisconsin's PV marketplace.

- *Is the company properly licensed?*

PV systems should be installed by appropriately licensed contractors. This usually means that either the installer or a subcontractor has an electrical contractor's license. The Wisconsin Department of Licensing, (608-266-2111) can tell you if a contractor has a valid electrician's license. Local building departments also may require that the installer have a general contractor's license. Consumers should call the city and county in which they live for additional information on licensing.

In 2003, a solar installer certification program will be implemented in Wisconsin. Finding a certified installer will help ensure that you receive a quality installation.

As with any construction project that requires a contractor, due diligence is recommended. To find out if the electrician is under any pending or active judgments or liens, contact the Wisconsin Better Business Bureau (414-273-1600), the Wisconsin Department of Licensing, or your city and county consumer protection organizations.

- *Is the lowest price the best deal?*

It might not be. Often, you get what you pay for. Remember that a PV company is a business just like any other, with overhead and operating expenses. It is always possible that a low price could be a sign of inexperience. Companies that plan to stay in business must charge enough for their products and services to cover their costs, plus a fair profit margin. Therefore, price should not be your only consideration.

How do I choose among competing bids?

Bids should include the following information:

- The total cost of getting the PV system up and running, including hardware, shipping, installation, connection to the grid, permitting, travel, sales tax and warranty.
- The generating capacity of the system (measured in watts or kilowatts). If possible, have the bids specify the system capacity in "AC (alternate current) watts," or specify the output of the system at the inverter.
- An estimate of the amount of energy that the system will produce on an annual basis (measured in kilowatt-hours). Because the amount of energy depends on the amount of sunlight—which varies by location, season and year to year—it is unrealistic to expect an exact estimate. A range of ± 15 percent is more realistic.
- A summary of building permit needs and costs.

If you get multiple bids for the installation of your PV system (and it is generally a good idea to do so), take steps to ensure that all of the bids you receive are made on the same basis. For example, comparing a bid for a system mounted on the ground against a bid for a rooftop system is like comparing apples to oranges.

Other questions that you may want to ask include:

- *Can you provide references from previous customers with similar systems?*
- *When will you be able to perform the work?*
- *How long will the project take?*
- *Do you provide an installation warranty, and if so, what are the details?*
- *How many similar systems have you installed?*
- *Have you worked with local building officials and utility representatives when installing similar systems in the past?*
- *Do you have a master electrician (or professional electrical engineer) as part of the project team?*
- *Will you hire subcontractors to complete portions of the project? What firms will you hire and what will they do?*
- *Do you repair systems that you installed, and if so, what are your rates?*
- *Will you train me to operate and maintain my system?*

The warranty is a very important factor for evaluating bids. Ask yourself, "What is the warranty period and will the business stand behind it?"

What about warranties?

Warranties are key to ensuring that your PV system will be repaired if something should malfunction during the warranty period. Realize that there are different types of warranties. Two key types are the installer's installation warranty and component manufacturer's warranty. Be sure that you understand what you have. Do they include only the cost of replacing the component, or does it also cover labor and shipping costs?

The system components such as the inverter, panels and rack should be covered by the manufacturer's warranty. Typically panels are warranted for 20 to 25 years and inverters are often warranted for five years.

Be sure you know who is responsible for honoring the various warranties associated with your system—the installer, the dealer or the manufacturer. The installer should disclose the warranty responsibility of each party. Get a clear understanding of which you should contact if there is a problem. To avoid any later misunderstandings, be sure to read the warranty carefully and review the terms and conditions with your retailer. Remember a warranty does not guarantee that the company will remain in business.

Before Purchasing a PV system

PV system owners are responsible for the design, installation, operation, and maintenance of their PV system. It is their responsibility to ensure the system conforms to all applicable codes, interconnection guidelines, service performance

requirements, and all relevant laws and regulations at the local, state, and federal levels.

What about permits?

Under Wisconsin State Law, any provision that prevents or unduly restricts the construction and operation of a solar energy system is “void.”¹⁴

Homeowners association codes

If you live in a community in which a homeowners association requires approval for a solar system, you or your PV provider may need to submit your plans. Gain approval from your homeowners association before you begin installing your PV system. An attractive solar electric roofing system may be easier to have approved.

Building permits

Most likely, you will need to obtain permits from your city or county building department. Wisconsin law prohibits undue regulation by counties, cities, villages or towns and outlines a process for solar access permits¹⁵. You will probably need a building permit, an electrical permit or both before installing a PV system. Typically, your PV installer will take care of this, and will include the price of the permits in the overall system price.

PV systems and the National Electrical Code

Code requirements for grid tied PV systems vary somewhat from one jurisdiction to the next, but most requirements are based on the National Electrical Code (NEC). The NEC has a special section, Article 690, which carefully spells out requirements for designing and installing safe, reliable, code-compliant PV systems. Because most local requirements are based on the NEC, your building inspector is likely to rely on Article 690 for guidance in determining whether your PV system has been properly designed and installed. If you are among the first in your community to install a grid-tied PV system, your local building department may not have approved one of these systems. If this is the case, you and your PV installer can speed the process by working closely and cooperatively with your local building officials to help educate them about the technology and its characteristics.

At this writing the Public Service Commission of Wisconsin is establishing Rules for standardized interconnection technical standards, application materials and procedures, and agreements¹⁶. All investor-owned and municipal electric utilities will use these standards statewide.

You will greatly ease the approval process for your PV system, both by local inspectors and your electric utility, if you use an inverter listed by a nationally recognized testing laboratory such as Underwriters Laboratory (UL).

¹⁴ See Wisconsin Statutes Ann. 236.292 (West 1994) and 66.031 (West 1982)

¹⁵ See Wisconsin Statutes 66.0401 and 66.0403

¹⁶ The Rules will be known as PSC 119, and available at www.legis.state.wi.us.

What about liability insurance?

Your electric provider will require you to enter into an interconnection agreement. This is described more fully in the next section. Usually, these agreements set forth minimum liability insurance requirements that you must keep in force. If you are buying a PV system for your home, your standard homeowner's liability insurance policy is usually adequate. However you will need \$300,000 of coverage for a system with a capacity of less than 20 kW.

Many insurance companies are unfamiliar with solar electric systems. A few of Wisconsin's insurance firms consider PV an unknown risk and are unwilling to provide liability insurance. If insurance coverage becomes an issue contact one of the groups under "Getting Help" at the end of this guide. There are several "PV-friendly" insurance firms in Wisconsin. The increase in the cost of your liability policy should only reflect the increased value of your property.

How do I get an interconnection agreement?

Under the federal Public Utility Regulatory Policies Act of 1978 (PURPA), all utilities must allow you to interconnect your PV system to the distribution grid.

Connecting your grid-tied PV system to the utility grid will require you to enter into an interconnection agreement with your electric provider. The Wisconsin Public Service Commission's regulations require utilities to supply you with an interconnection agreement. It is recommended that you work with your PV installer to complete the application materials.

Contact your electric provider before purchasing your system. Your electric provider should give you the application materials and the Wisconsin Interconnection Guidelines. The guidelines spell out the interconnection-related technical and business issues including fees, the interconnection process, and insurance and technical requirements. They also include an application and interconnection agreement.

The interconnection agreement specifies the terms and conditions under which your system will be connected to the utility grid. These will include your obligation to build the system to code, obtain insurance, maintain the system in good working order and operate it safely. If you are unclear about your obligations under the interconnection agreements, you should contact your electrical service provider for clarification. If your questions are not adequately addressed, contact one of the groups under Further Resources at the end of this guide.

Approach your electric provider in a friendly manner and you may find that they are excited to work with you and learn from your PV system.

Who pays for interconnecting?

For customers of investor-owned and municipal utilities with PV systems of 20 kW or less there is no cost to interconnect a system. There are no application,

study, or interconnection fees. The only costs may be the purchase of a new electric meter and any distribution system upgrades that may be required.

How do I get a net energy billing?

Investor-owned utilities in Wisconsin are required to offer customers, with grid-tied PV systems of 20 kW or less, net energy billing. When a PV system generates more power than the site needs, the electric provider credits the customer.

Net energy billing allows eligible customers with PV systems to connect to the grid with a single meter. Some utility meters are able to measure the flow of energy in either direction. The meter spins forward when electricity is flowing from the utility into the building and spins backward when power is flowing from the building to the utility. However, it is possible that the electric provider may require more than one meter: one to measure the flow of electricity into the building, the other to measure the flow of electricity out of the building. Customers are billed monthly for the “net” energy consumed. If the customer’s net consumption is negative in any month (i.e. the PV system produces more energy than the customer uses), the balance is either paid or credited to the next month’s bill depending on the electric provider. When credited once a year the books are closed and any remaining credit will either be ignored, paid at the retail rate or avoided cost, depending on the utility.

If, like most of Wisconsin’s electric cooperatives, your electric provider does not offer net energy billing, it will probably require you to use two meters and the electric provider will only pay you their avoided cost rate for your excess electricity. In this case, you will have a strong incentive to use all the electricity you generate to offset electricity purchases. This may be a factor in how you optimize your system size, because you may want to limit the excess electricity you generate.

If you receive electricity from a small utility, you may find that you are the first person to approach the electric provider about interconnection and net energy billing. Many smaller utilities, especially rural electric cooperatives, do not have net energy billing policies in place and may handle each request on an individual basis.

What about utility and inspection sign-off?

In most cities after your PV system is installed, it must be inspected and approved by the local permitting agency (usually a building or electrical inspector). It may also be tested by your electric provider. Inspectors may require your PV provider to make corrections, but do not be alarmed—this is fairly common in the construction business. Often your PV system will be the first that an inspector or utility representative has seen, so be available to describe the system and show how it meets code.

What are the steps for getting a PV system installed?

1. Inform yourself.
2. Design, specify and price a system. It is best to do this with your PV system provider.
3. Get all approvals from:
 - Neighborhood association (if needed)
 - Electric provider (send in completed interconnection application form)
 - Community building permit department, and
 - Insurance agent.
4. Apply for Focus on Energy incentives (if eligible and available).
5. Order, and install system.
6. Complete interconnection agreement with your electricity provider, adjust the value of your insured property with your insurance company, and send in paper work for Focus on Energy incentive.

Further Resources

To receive more information about solar electric systems, please contact:

<p>Focus on Energy Renewable Energy Program 800 762-7077 focusonenergy.com</p>	<p>A public-private partnership offering energy information and services to electric utility customers in Wisconsin. Renewable Energy program seeks to raise awareness, provide training and financing, enhance marketing, promote technical assistance and support the installation of renewable energy technologies.</p>
<p>WisconSUN www.wisconsun.org Wolter@msbnrg.com 608 831-1127 ext. 308</p>	<p>Created to coordinate and promote the use of solar energy systems in Wisconsin, with a focus on PV systems. WisconSUN promotes solar energy projects by marketing, reducing barriers, and helping participants. We support projects during planning, design, and installation. We also provide the information, training, and project management assistance needed to implement these systems successfully.</p>
<p>Wisconsin Division of Energy www.doa.state.wi.us/energy energy@doa.state.wi.us 608 266-8234</p>	<p>Advises the governor and legislature on policies and programs for state and regional energy management, administers federal and state energy efficiency funds (including the Focus on Energy Program), and develops and coordinates emergency energy policies and programs. Analysts maintain up-to-date information on availability, use, prices and regulatory issues for oil, gas, coal, renewable energy resources and energy efficiency techniques.</p>
<p>Public Service Commission of Wisconsin www.pscw.wi.gov 608 267-2896</p>	<p>Independent regulatory agency dedicated to serving the public interest. The agency is responsible for the regulation of Wisconsin public utilities, including those that are municipally owned.</p>
<p>Midwest Renewable Energy Association www.the-mrea.org (715) 592-6595 mreainfo@wi-net.com</p>	<p>A nonprofit network for sharing ideas, resources and information with individuals, businesses and communities to promote a sustainable future through renewable energy and energy efficiency.</p>